

Voltage	Prime*	
	kVA	kW
380-415	250	200

Standby*		Ampere
kVA	kW	
275	220	348

Prime Rating Applicable for supplying continuous electrical power at variable load for unlimited hours. This model can supply 10% overload power for a period of 1 hour in 12 hours operation as it is defined in ISO 3046.

Standby Rating Applicable for supplying continuous power at variable load in the event of a utility power failure and overload is not allowed as it is defined in ISO 8528-3.

Standard Generator Features

- ◊ AMF, Automatic mains failure unit
- ◊ Heavy duty type, 6 cylinder, water cooled engine
- ◊ 50°C tropical type radiator
- ◊ Starter motor
- ◊ Lead acid battery
- ◊ Charging alternator
- ◊ Battery charge redressor
- ◊ Heavy duty, brushless type alternator
- ◊ Base frame with anti-vibration units
- ◊ Industrial type silencers
- ◊ Flexible exhaust compensator
- ◊ Block water heater unit
- ◊ Control panel with digital-automatic main control module
- ◊ Fan, fan drive, charging alternator drive and all rotating parts covered
- ◊ Radiator matrix covered by metal mesh against the mechanical damages
- ◊ Fabricated and welded steel base frame
- ◊ Anti-vibration mountings
- ◊ Engine and alternator manufacturer test reports
- ◊ Factory load, performance and function tests

Optional Features

- ◊ Automatic load transfer panel
- ◊ Automatic synchronization and power sharing systems
- ◊ Soundproof canopy
- ◊ Container type enclosures
- ◊ Road trailer
- ◊ Job-site trailer
- ◊ Protection circuit breaker
- ◊ Air start
- ◊ Remote type radiator
- ◊ Base fuel tank
- ◊ External type fuel tank
- ◊ Automatic fuel transfer system
- ◊ Residential silencer

Dimensions & Weight

Open Type	Dry Weight kg	Length mm	Width mm	Height mm	Tank Capacity L
KZS250PS	2200	2750	1000	1800	400
Sound Attenuated	Dry Weight kg	Length mm	Width mm	Height mm	Tank Capacity L
KZS250PS	2950	4000	1200	2200	720

K.U.N.Z. Handels-&Produktions GmbH

Headquarter
Oskar-von-Müller-Strasse 29
68309 Mannheim, Deutschland
Tel. : +49 621 - 76 217 733
Faks: +49 621 - 76 217 734

U.K. Branch
1 Canada Square Canary Wharf, Floor 37
London, United Kingdom
Tel. : +44 (0) 20 7718 0185
Faks: +44 (0) 20 7718 0001

Turkey Branch
Mansuroglu Mh. 295/2 Sk. Ege Sun Plaza
A Blok No:1 K:6 D:652 Bayraklı, 35535
Izmir
Telefax. : +90 232 461 66 91

Truly Global, Fully Reliable

Engine Technical Data

Manufacturer	PERKINS
Model	1306C-E87TAG6
Type	4 cycle, water-cooled
Number of cylinders	6
Cylinder arrangement	Vertical in-line
Displacement, Liters	8,7
Bore X Stroke, mm	116,6 X 135,9
Compression Ratio	16,9:1
Combustion System	Direct injection
Aspiration	Turbocharged, air to air cooled
Rotation	Anticlockwise viewed on flywheel
Gross engine power, kWb	246
Fan Power, kWm	7
BMEP gross, bar	22,61
Combustion air flow, m ³ / min	16,4
Exhaust gas temp.(after turbo), °C	528
Exhaust gas flow (after turbo),m ³ / n	44,5
Mean piston speed, m / s	6,8

Fuel System

Type of injection system	Direct injection
Fuel atomiser	Heui
Fuel injection Pump	Bosch
Delivery/hour at 1500rev/min, Lt	180
Governor type	Electronic
◊ Electronic governing to ISO3046-4 with stand alone isochronous or load sharing capabilities	
◊ Hydraulically actuated electronically controlled unit fuel injectors with full authority electronic control	
◊ Spin on fuel filter with pre filter and hand primer pump	

Electrical System

Alternator	24 Volt, Lucas AC5R, 45 Amp
Starter motor (DC)	24 Volt Lucas S115
◊ Electronic Control Module mounted on engine with wiring looms and sensors	
◊ Three level engine protection system	

Cooling System

Type	Tropical, heavy duty type
Ambient temperature, °C	50
Engine&Radiator coolant capacity	37,22
Pressure cap setting, kPa	68,9
◊ Thermostatically-controlled system with belt driven circulating pump and 28 inch belt-driven fan	
◊ Radiator mounted with all guards and pipes	
◊ Air to air charge cooler incorporated in radiator	
◊ Coolant filter and conditioner	

Lubrication System

Type	Pressurized
Capacity, Liters	28,3
Lub oil pressure (min), kPa	552
◊ Wet rear well steel sump with filler and disptick	
◊ Full-flow spin on filter	
◊ Tube type oil cooler thermostatically controlled	

Fuel Consumption

liters per hour	% 110 Load	59,9 L
	% 100 Load	45 L
	% 75 Load	36 L
	% 50 Load	24 L
grams per kWh	% 110 Load	204,5 g/kWh
	% 100 Load	206,2 g/kWh
	% 75 Load	210 g/kWh
	% 50 Load	215,2 g/kWh

Model	Standby kW		Prime kW	
	Gross	Net	Gross	Net
1306C-E87TAG6	246	239	224	217

K.U.N.Z. Handels-&Produktions GmbH

Headquarter
 Oskar-von-Miller-Strasse 29
 68309 Mannheim, Deutschland
 Tel. : +49 621 - 76 217 733
 Faks: +49 621 - 76 217 734

U.K. Branch
 1 Canada Square Canary Wharf, Floor 37
 London, United Kingdom
 Tel. : +44 (0) 20 7718 0185
 Faks: +44 (0) 20 7718 0001

Turkey Branch
 Mansuroglu Mh. 295/2 Sk. Ege Sun Plaza
 A Blok No:1 K-6 D:652 Bayraklı, 35535
 İzmir
 Telefax. : +90 232 461 66 91

Truly Global, Fully Reliable

Alternator Technical Data

Manufacturer	STAMFORD
Model	UCDI274K
Type	4-Poles, Rotating Field, Brushless
Standby power at rated voltage, kVA	275
Efficiency, %	92,2
Power factor	0.8
Phase	3
Frequency, Hz	50
Speed, Rpm	1500
Voltage, V	380/415
Excitation	Self excited
Stator windings	2/3 Pitch factor
Regulation	AVR, Auto Voltage Regulator
Voltage Regulator	SX460
Voltage Regulation, %	± 1
R.F.I Suppression	BS EN 61000-6-2, BS EN 61000-6-4 VDE0875G, VDE 0875N
Waveform distortion	No Load <1.5% Non distorting balanced
Rotor	Dynamic balanced
Overspeed, Rpm	2250
Short circuit current	< 300%
TIF	Less than 50
Insulation class	H
Construction	Single bearing, direct coupled
Coupling	Flexible
Stator winding	Double layer concentric
Connection	WYE
Protection class	IP23
Cooling air volume, m ³ / sec	0,58

Winding & Electrical Performance

All generator stators are wound to 2/3 pitch. This eliminates triplen harmonics on the voltage waveform and is found to be the optimum design for trouble-free supply of non-linear loads. The 2/3 pitch design avoids excessive neutral currents sometimes seen with higher winding pitches, when in parallel with the mains. A fully connected damper winding reduces oscillations during paralleling. This winding, with the 2/3 pitch and carefully selected pole and tooth designs, ensures very low waveform distortion.

Quality Assurance

Generators are manufactured using production procedures having a quality assurance level to BS EN ISO 9001.

Optional Equipment

- ◊ Optional Permanent Magnet Generator (PMG) provides an isolated power supply to the excitation control system
- ◊ Anti Condensation Heaters
- ◊ Air Filters
- ◊ Temperature Indication RTD's
- ◊ Winding Protection Thermistors
- ◊ Quadrature Droop kit for Parallel Operation
- ◊ SX421 AVR with 3 Phase Sensing and improved Regulation 0.5%
- ◊ MX341 (PMG) 1% Regulation with 2 Phase Sensing
- ◊ MX321 (PMG) with 3 Phase Sensing and improved Regulation 0.5%

Terminals & Terminal Box

Standard generators feature a main stator with 6 ends brought out to the terminals, which are mounted on the frame at the non-drive end of the generator. A sheet steel terminal box contains the AVR and provides ample space for the customer's wiring and gland arrangements. It has removable panels for easy access.

Shaft & Keys

All generator rotors are dynamically balanced to better than BS6861 Part 1 Grade 2.5 for minimum vibration in operation. Two bearing generators are balanced with a half key.

Insulation / Impregnation

The insulation system is class 'H'. All wound components are impregnated with materials and processes designed specifically to provide the high build required for static windings and the high mechanical strength required for rotating components.

Standards

Newage Stamford industrial generators meet the requirements of BS EN 60034 and the relevant section of other international standards such as BS5000, VDE0530, NEMA MG1-32, IEC34, CSA C22.2-100, AS1359. Other standards and certifications can be considered on request.

Model	Standby		Prime	
	kVA	kW	kVA	kW
UCDI274K	275	220	250	200

K.U.N.Z. Handels-&Produktions GmbH

Headquarter
 Oskar-von-Miller-Strasse 29
 68309 Mannheim, Deutschland
 Tel. : +49 621 - 76 217 733
 Faks: +49 621 - 76 217 734

U.K. Branch
 1 Canada Square Canary Wharf, Floor 37
 London, United Kingdom
 Tel. : +44 (0) 20 7718 0185
 Faks: +44 (0) 20 7718 0001

Turkey Branch
 Mansuroglu Mh. 295/2 Sk. Ege Sun Plaza
 A Blok No:1 K-6 D:652 Bayraklı, 35535
 İzmir
 Telefax. : +90 232 461 66 91

Truly Global, Fully Reliable

Deepsea 7320 Control System
Description

- ◊ Deepsea 7320 is an Auto Mains(Utility) Failure Control module.
- ◊ The module is used to monitor a mains supply and automatically start a standby generator set.
- ◊ The module can also monitor an extensive number of engine parameters and it can display warnings, shutdown and engine status information on the back-lit LCD screen, illuminated LEDs, remote PC and via SMS text alerts.
- ◊ Selected timers and alarms can be altered by the user from the front panel.
- ◊ Alterations to the system are made using the 810 interface and a PC and it also provides real time diagnostic facilities

Specification

DC SUPPLY

Continuous Voltage Rating: 8 V to 35 V
 Maximum Operating Current: 340 mA at 12 V, 160 mA at 24 V
 Maximum Standby Current: 160 mA at 12 V, 80 mA at 24 V
 Charge Fail/Excitation Range: 0 V to 35 V

MAINS(UTILITY) & GENERATOR

Voltage Range: 15 V - 333 V AC (L-N)
 Frequency Range: 3,5 Hz to 75 Hz

OUTPUTS

Output A (Fuel): 15 A DC at supply voltage
 Output B (Start): 15 A DC at supply voltage
 Output C & D : 8 A 250 V (Volt free)

Input Functions display on LCD

Generator Volts	Volts	L1-N, L2-N, L3-N
Generator Volts	Volts	L1-L2, L2-L3, L3-L1
Generator Amps	Amps	L1, L2, L3
Generator Frequency	Hz	
Mains Volts	Volts	L1-N, L2-N, L3-N
Mains Volts	Volts	L1-L2, L2-L3, L3-L1
Mains Frequency	Hz	
Engine Speed	RPM	
Plant Battery Volts	Volts	
Engine Hours Run	Hour	
Generator total power	kVA	L1, L2, L3,total
Generator total power	kW	L1, L2, L3,total
Generator power factor	Cosφ	L1, L2, L3,total

Features

- 4-Line back-lit LCD text display and five key menu navigation
- LED and LCD alarm indication
- 9 configurable inputs and 8 configurable outputs
- Configurable timers, alarms and event log (250)
- Fuel usage monitor and low fuel alarms
- Charge alternator failure alarm
- Manual speed and manual fuel pump control
- Engine exerciser and "Protections disabled" feature
- kW overload protection
- Power monitoring (kW, h, kV Ar, kv A h, kV Ar h)
- Load switching (load shedding and dummy load outputs)
- Automatic load transfer and unbalanced load protection
- Independent Earth Fault trip
- Support for up to three remote display units and USB connectivity
- Configurable display languages
- Remote SCADA monitoring
- User selectable RS232 and RS485 communications
- SMS messaging (external modem required)
- Additional display screens to help with modem diagnostics

Alarm Channels

- Under/over generator voltage
- Over-current
- Under/over generator frequency
- Under/over speed
- Charge fail
- Emergency stop
- Low oil pressure
- High engine temperature
- Fail to start
- Low/high DC battery voltage
- Reverse power
- Generator phase rotation error
- Generator short-circuit protection
- Loss of speed sensing signal
- Mains out of limits

Optional Input Functions

Engine Oil pressure	kPa
Fuel level	%
Engine Temperature	°C

K.U.N.Z. Handels-&Produktions GmbH

Headquarter

Oskar-von-Miller-Strasse 29
 68309 Mannheim, Deutschland
 Tel. : +49 621 - 76 217 733
 Faks: +49 621 - 76 217 734

U.K. Branch

1 Canada Square Canary Wharf, Floor 37
 London, United Kingdom
 Tel. : +44 (0) 20 7718 0185
 Faks: +44 (0) 20 7718 0001

Turkey Branch

Mansuroglu Mh. 295/2 Sk. Ege Sun Plaza
 A Blok No:1 K:6 D:652 Bayraklı, 35535
 İzmir
 Telefax. : +90 232 461 66 91

Truly Global, Fully Reliable

Model Codes and General Information

Kunz Diesel Generator

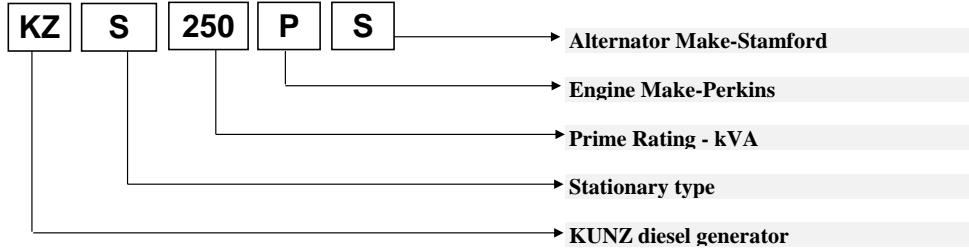

Perkins 1300 Series Diesel Engine

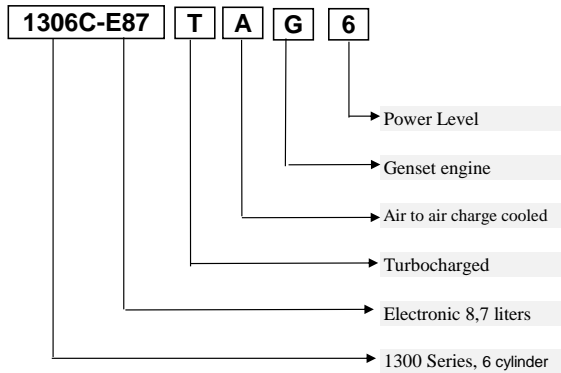

Newage / Stamford Alternator

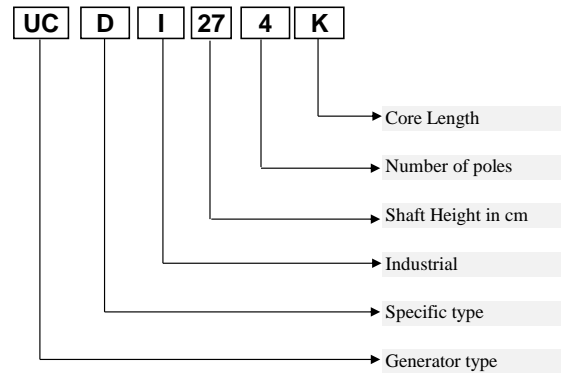

K.U.N.Z. Handels-&Produktions GmbH

Headquarter
 Oskar-von-Miller-Strasse 29
 68309 Mannheim, Deutschland
 Tel. : +49 621 - 76 217 733
 Faks: +49 621 - 76 217 734

U.K. Branch
 1 Canada Square Canary Wharf, Floor 37
 London, United Kingdom
 Tel. : +44 (0) 20 7718 0185
 Faks: +44 (0) 20 7718 0001

Turkey Branch
 Mansuroglu Mh. 295/2 Sk. Ege Sun Plaza
 A Blok No:1 K-6 D:652 Bayraklı, 35535
 İzmir
 Telefax. : +90 232 461 66 91

Truly Global, Fully Reliable